

# International Survey on Copyright Levies

**Legal Monitoring and Services of K&L GmbH**

March 2009

## Complete and Updated Surveys

- Origins of Copyright Levies for Private Copying
- Payment Flows and Principles of the Implementation Process

## Consulting and Services

- Legal Definitions and Obligations
- Tariffs and Legal Basis
- Reporting Requirements
- Registration and Reporting

## Copyright Levies do have a long history in Europe

- Levies for private copying ≠ royalty payments/licence fees
- Royalties for publication and/or use of protected works since the 19th century
- Copyright Levies for devices and blank media e.g. in Germany: for analogue equipment since 1960; for digital (scanner) since 1995
- New technologies permit uncontrolled use, storage and duplication of protected works by private users
- Digital techniques permit large scale uncontrolled use even without quality loss
- European Directive on Copyright Levies became effective in 2001 aiming at a harmonisation of national legislations across the EU
- The new systems are based on the load of the devices and blank media suitable for private copying

## Electronic products and Storage Media are subject to Copyright Levies according to EU directive 2001/29/EC

Legislations, however, both in EU and non-EU countries differ in many aspects:

- segments covered (products + storage media)
- amounts of levies
- deadlines and dates
- payment conditions
- special conditions
- responsible authorities
- [...]

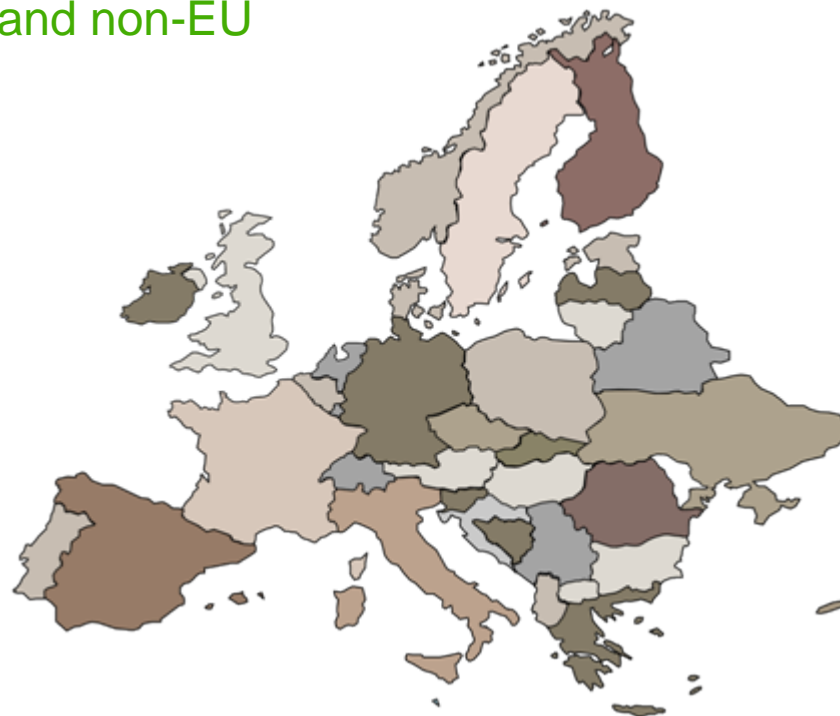

Based on the EC Directive „On Certain Aspects of Copyright and Related Rights“ (2001/29/EC), EU-Member States are about to introduce Copyright Levies on digital equipment such as:

### **Reprography**

- Copiers
- Printers
- Handheld Scanners
- Flatbed Scanners
- Sheetfeed Scanners
- Fax Machines
- MFDs / AIOs

### **Analogue Equipment**

- VHS Recorder
- Cassette Recorder

### **Analogue Media**

- Audio Cassette
- VHS Cassette

### **Digital Equipment**

- Personal Computer
- CD/DVD Writer
- Hard Disk
- External Hard Disk
- USB Stick
- Memory Card
- MP3-Player
- Devices with integrated storage media
- Mobile Phone with integrated memory

### **Digital media**

- CD-R, CD-RW, DVD-R, DVD-RW,
- DVD+R, DVD+RW, DVD RAM, Double Layer DVD
- MiniDisk
- New Formats: Blu Ray Disc, HD DVD

## National Legal Framework

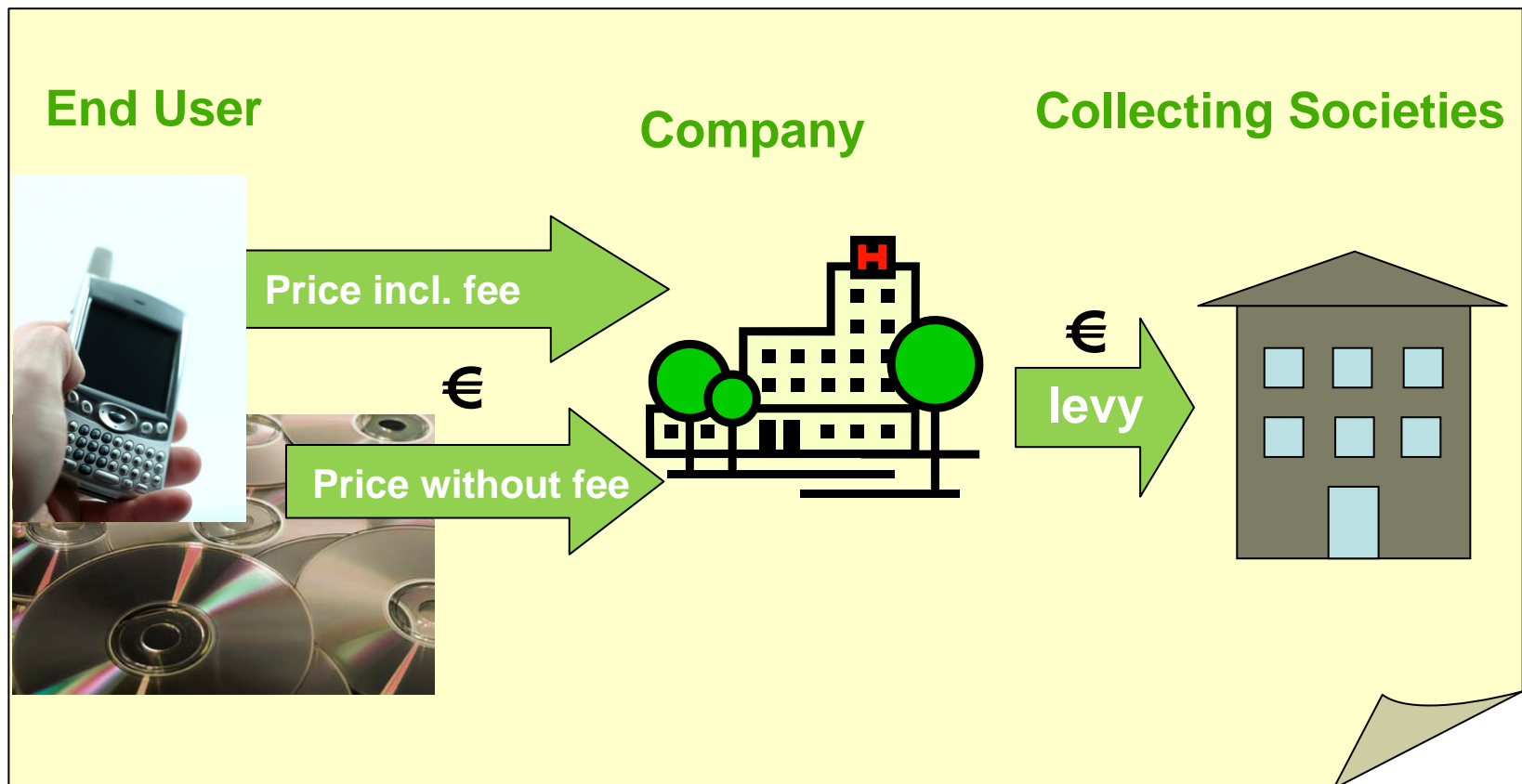

## National Legal Framework

### Obliged Parties

- Licence holders (event presenter, advertisers, publishing houses ...)
- Manufacturer and importer of equipment for private copying
- [ ... ]

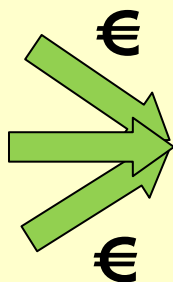

### Collecting Societies

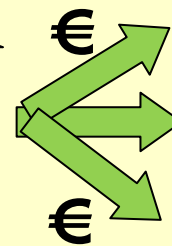
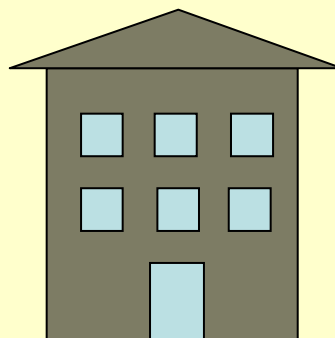

### Authors & Artists



Copyright Levies (scope and tariffs) vary enormously across the European Union.

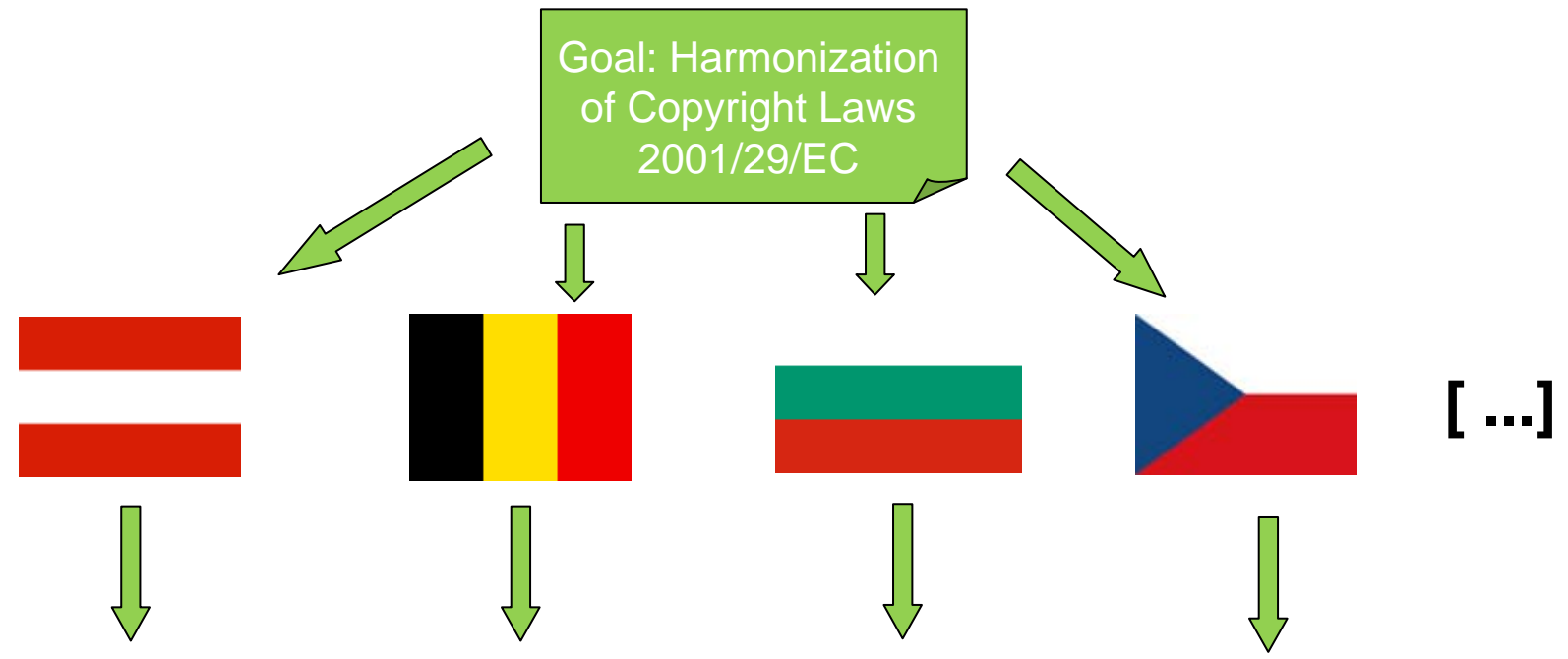

Different Scopes, Legal Frameworks, Reporting Requirements ...

Government or national commissions set the levy rates on equipment and media – or decide not to include them in the scope.

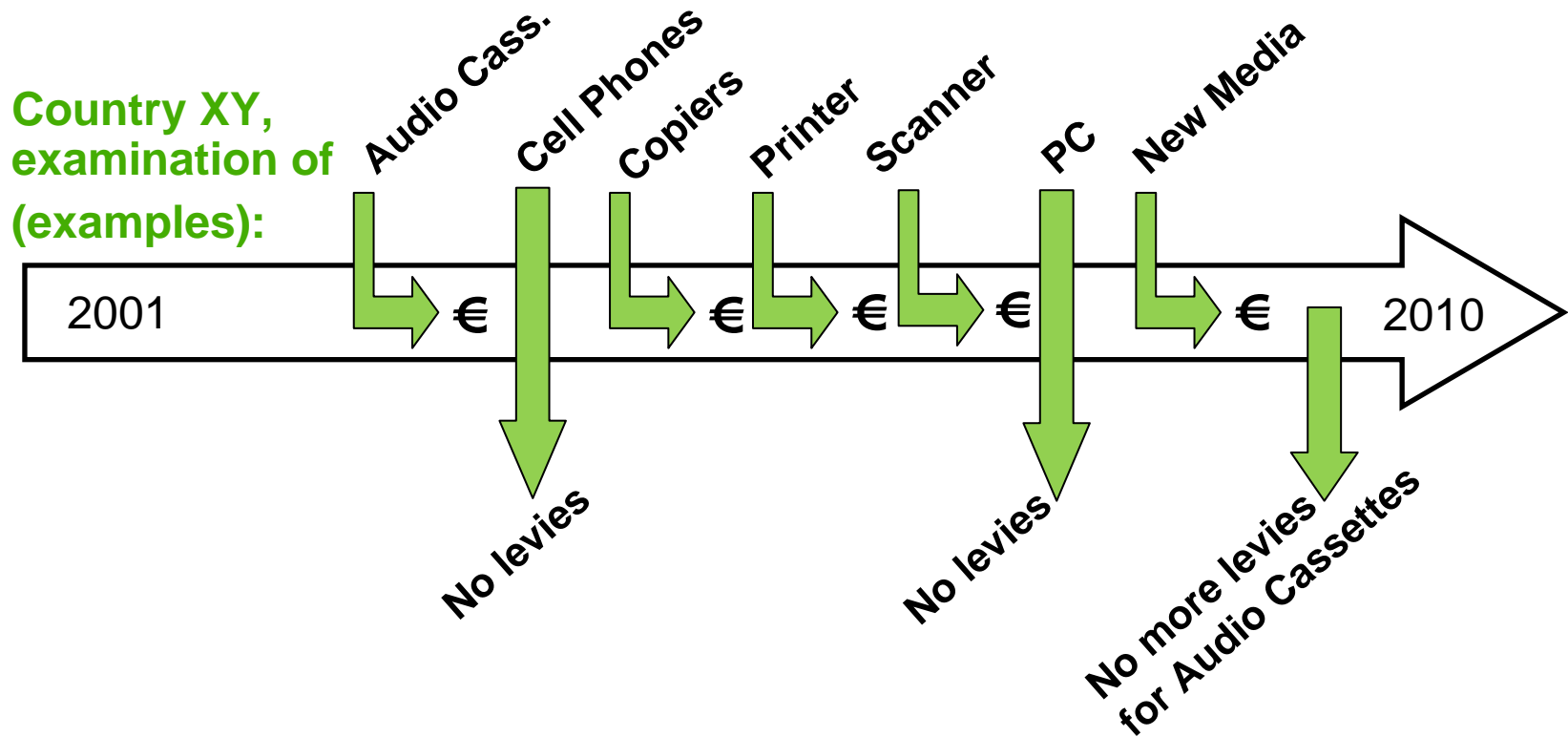

- Industry and the competent authorities constantly negotiate on the remunerations
- Technical and legal questions play a role in the determination of the levies
- Numerous claims are even subject to law suits
- Each day both in Europe and in rest of the world regulations, tariff amounts or formalities change
- Technical progress and the business development of the IT- and CE-industry constantly demand changes and adjustments of the national legislations

The informal determination of levies regarding a specific enterprise considers all negotiations and contracts which have yet not become legal guidelines, but are relevant for practice.

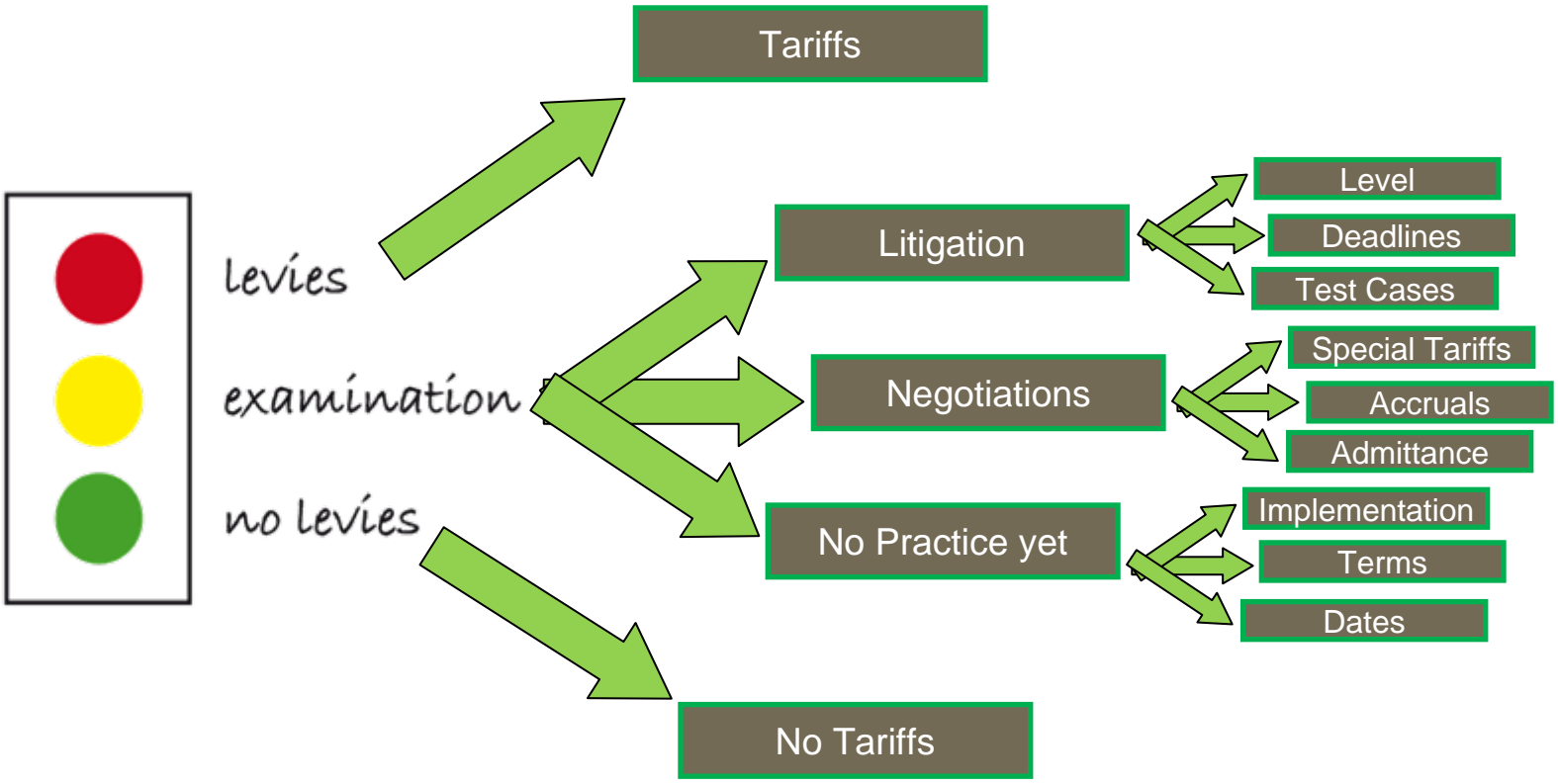

# Identification of Formal Obligations

Company obliged?   Enforcement abroad?   Which countries?   Tariffs per Product?   Contractual Tariffs?   Refunds? [...]

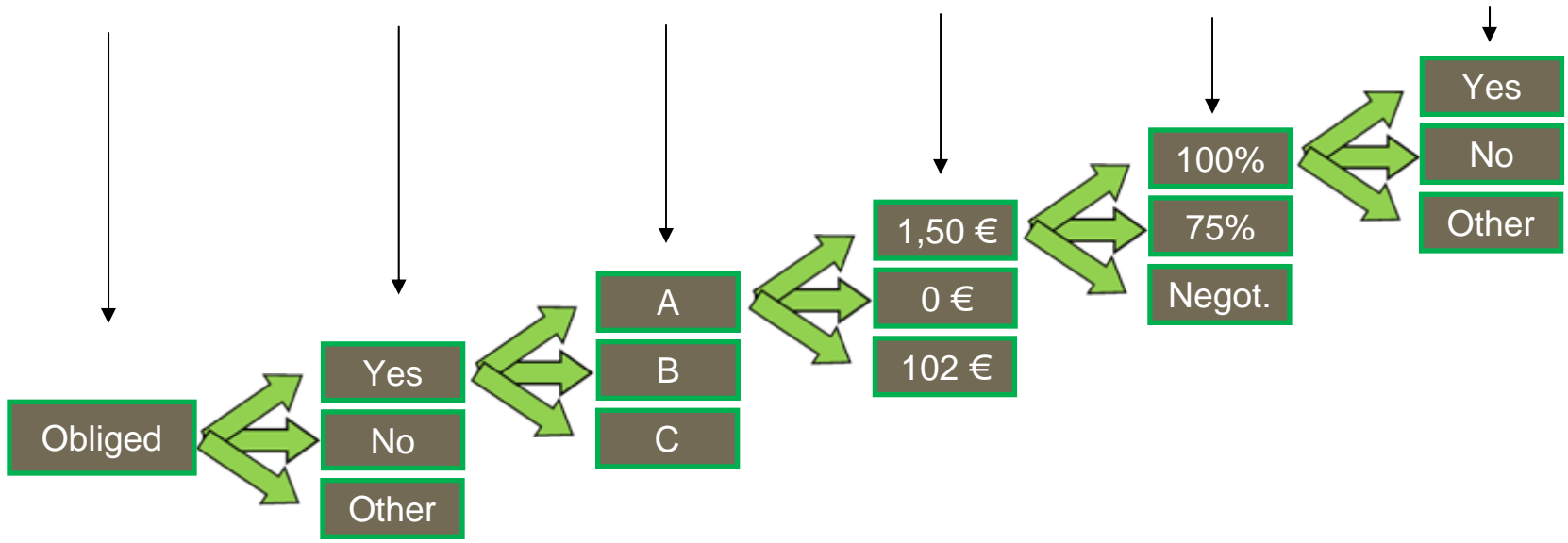

Checked for company by K&L

Recommendations per

- Product/Category
- Country

For any recommendation, we have to know if the agreements about tariffs and payment terms are put in place or pending

- For our legal analysis we are in contact with Collection Societies and Industry Associations
- It is common practice for both parties to agree contractually about tariffs and payment terms on the basis of the applicable legal provisions
- Such negotiations may take time because of
  - Divergent economic and legal positions and/or
  - Court cases about Copyright Levies
- K&L is currently collecting information about agreements and negotiations between collection societies and industry
- Many of those organisations are not very responsive

## Checks ⇒ Litigations ⇒ Individual Contracts ⇒ Special Tariffs ⇒ Exemptions?

For the identification of a company's individual obligations – country by country, product by product – it is necessary to negotiate with the different stakeholders

- ⇒ Which contracts/agreements have been negotiated?
- ⇒ Which contracts/agreements are being negotiated at present?
- ⇒ Under which conditions can the company join?
- ⇒ Organizational questions: Terms and conditions?

### **Note:**

- There are just as many industry associations as collecting societies.
- The role and the statements of the arbitration boards are to be considered.
- Large enterprises are other important participants, e. g. they provide test cases for law suits.
- There are negotiations on national and on European level.



## K&L provides Consulting and Compliance Services for IT & CE Industry

- Survey on national legislations  
EU 27 + 8 worldwide
- Large Database
- Monitoring of Changes
- Legal Recommendations
- Definitions
- Obligations
- Special requirements
- Registration and Reporting



## European Landscape: Product Levies or not?

The determination of levies is a sequential process in all European countries and in many other countries worldwide.

K&L shows you, with consideration of equipment category and product, where products are levied, where levies are currently under negotiation, and where there are still none.

	CD, DVD, Blu Ray	MP3, Mobile Phones	Copiers, Faxes
Country A	●	●	●
Country B	●	●	●
Country C	●	●	●

●	levies
●	examination
●	no levies

The K&L International Survey on Copyright Levies depicts legal provisions for Copyright Levies in all EU-countries and additional countries worldwide. Some regulations leave room for interpretation in favour or to the disadvantage of a manufacturer, importer, assembler, wholesaler, retailer, distant seller etc. In most countries the regulations and calculations vary and many questions need to be clarified.

## Examples:

- Listing of new products, convergence and higher capacities?
- Calculation of the tariffs – per unit, per minute or in a corridor?
- Pricing – what are the price definitions, which price is applicable, how is it ascertained?
- Scope – which devices are included exactly, which are not?
- Responsibilities, structure and organization of the collecting systems?
- Possibilities for refunding?
- Display of the fees on invoices?
- ... and many more

# Obligations per Business Model

**Company**

**Country**

**Obligations**

- Individual
- Product Scope
- Manufacturing
- Importing
- Brand Reselling
- Free Entrepots
- Distant Selling
- Central Invoicing



- EU:** Netherlands
- Austria
- Belgium
- Bulgaria
- Cyprus
- Czech Rep.
- Denmark
- Estonia
- Finland
- France
- Germany
- Greece
- Hungary
- Ireland
- Italy
- Latvia
- Lithuania
- Luxembourg
- Malta
- Poland
- Portugal
- Romania
- Slovakia
- Slovenia
- Spain
- Sweden
- UK
- Worldwide:**
- Canada
- Croatia
- Norway
- Russia
- Switzerland
- Turkey
- Ukraine
- USA



Even the organization of the levy systems shows national varieties:

- Formats
- Frequencies
- Payments
- Time frames
- Required Information
- Additional Information



K&L points out all organizational requirements in the countries

## Do exemptions exist?

Not all products are levied. But there are additional reasons not to pay:

**Export** – cross-border trade and e-commerce issues

**Professional Use** – how should collecting societies differentiate?

The national legislations in the EU countries differ from each other also in this area. They are disputed very much at the moment. Both the commission and the industry pursue the questions.

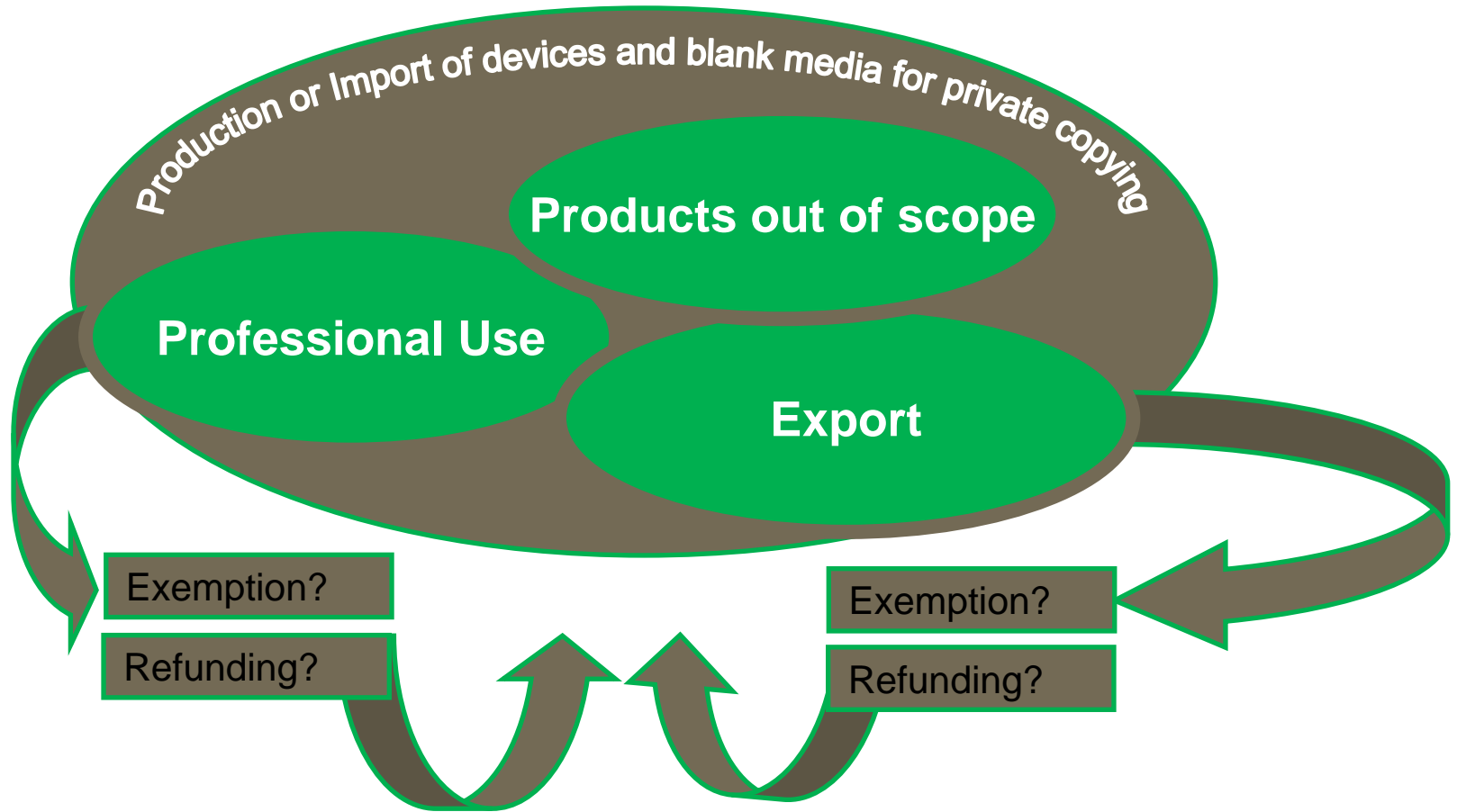



## **Make or Buy: Consulting & Service of K&L in this field of international legislation save you a lot of effort and uncertainties**

- ⇒ We monitor dynamic legislations driven by industry, collectors, end-users, artists and many other participants
- ⇒ We permanently update know-how and facts for our customers
- ⇒ We provide orientation for heterogeneous structures of 35 different national legislations
- ⇒ We continuously perform complex researches in 35 countries
- ⇒ We work on the basis of disparate experiences and competences

**Stay compliant in a very complex and demanding field!**

# Thank you for your attention!

Further questions to:

K&L GmbH

Wolfram Kühn

Tel.: +49 (7071) 257000-62

[kuehn@kc-cc.de](mailto:kuehn@kc-cc.de)

[www.kl-cc.de](http://www.kl-cc.de)